



GalvanoTest 3000

Technical Reference and Operating Manual

Advancing with Technology **ElektroPhysik**

© 12/2003 B18-N

Technische Änderungen vorbehalten.

Subject to change without notice.

ElektroPhysik Dr. Steingroever GmbH & Co. KG

Pasteurstr. 15

50735 Köln

Deutschland

Tel.: +49 221 752040

Fax.: +49 221 7520467

web: www.elektrophysik.com

Table of Contents

1. Description	D-1
1.1 Data processing unit (Front view)	D-1
1.2 Data Processing Unit (Back view)	D-2
1.3 Measuring stand with integrated circulation pump	D-5
1.4 Measuring cell 3000 and fasteners	D-7
2. Introduction	D-8
2.1 General Usage and measuring principle	D-8
2.2 Description	D-9
3. Supply schedule	D-10
3.1 Standard supply	D-10
3.2 Recommended accessories	D-11
4. Taking Readings	D-12
4.1 Adjusting the instrument	D-12
4.1.1 Metal coating material (METAL) ...	D-12
4.1.2 Measuring area (AREA)	D-12
4.1.3 Deplating speed control (SPEED) ..	D-13
4.1.4 Sensitivity (SENS)	D-13
4.1.5 Calibration (CAL)	D-14
4.1.6 Measuring unit (UNIT)	D-14
4.2 Preparing measurement	D-15
4.2.1 Cleaning the sample	D-15
4.2.2 Positioning the sample	D-15
4.2.3 Elektrolyt selection table	D-16
4.2.4 Choosing electrolyte and measuring cell	D-17
4.2.5 Filling in the electrolyte solution	D-17
4.3 Taking readings	D-17
4.4 After measurement	D-18
4.4.1 Electrolyte saturation	D-19
4.4.2 Y-T writer output	D-19

4.5 Printing out readings	D-20	8.4 Multi-layer coatings	D-30
4.5.1 Print-out of voltage curve	D-20	8.5 Chromed zinc coatings	D-31
4.5.2 Readings and statistics	D-21	8.6 Diffusion layers	D-32
5. Measuring stand and accessories .	D-22	8.7 Currentless nickel	D-32
5.1 Centering device	D-23	8.8 Nickel on copper on steel	D-33
5.2 Positioning arm	D-23	8.9 Copper on zinc	D-33
6. Small parts holder	D-24	8.10 Tin on brass	D-33
7. Electrolyte cup.....	D-24	8.11 Thick coatings	D-33
7.1 Variable measuring area	D-25	9. Calibration	D-34
7.2 "C" Mask	D-28	9.1 Calibrating by means of a coating thickness standards	D-34
8. Special applications	D-29	9.2 Calibrating by means of a factor	D-35
8.1 Convex surfaces	D-29	9.3 Range of calibration factor	D-35
8.2 Concave surfaces	D-30	9.4 Reset to standard calibration (1.000)	D-35
8.3 Gold coatings (Au)	D-30		

10. Sensitivity (SENS)	D-36	15. Error messages	D-40
10.1 Reset to standard sensitivity	D-36	16. Further sources of error	D-41
11. Measuring uncertainty	D-37	17. Maintenance	D-42
11.1 Error sources	D-37	18. Data Printer MiniPrint 4100	D-43
12. Statistics mode	D-37	19. RS 232 C Interface	D-43
12.1 Recording a measuring series and statistics calculation	D-38	20. After sales service	D-43
12.2 Recalling and print-out of statistics	D-38	21. Hints for using electrolyte solutions	D-43
12.3 Print-out of readings and statistics	D-38	22. Technical specifications	D-44
12.4 Deleting a previous reading.....	D-38	22.1 Measuring uncertainty	D-45
12.5 Deleting a measuring series incl. statistics		Index	D-46
12.6 Exceeding storage capacity	D-39		
13. Date and Time	D-39		
14. Language selection	D-40		

1. Description

1.1 Data processing unit (Front view)

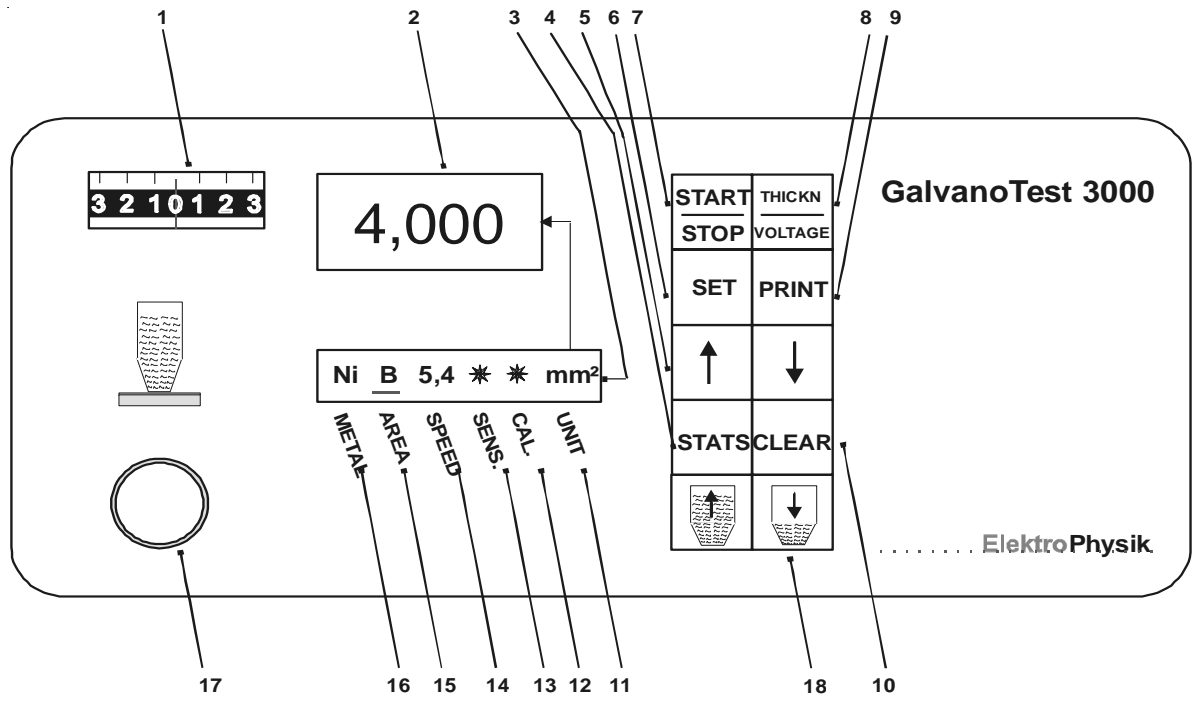

Fig. 1

1.2 Data Processing Unit (Back view)

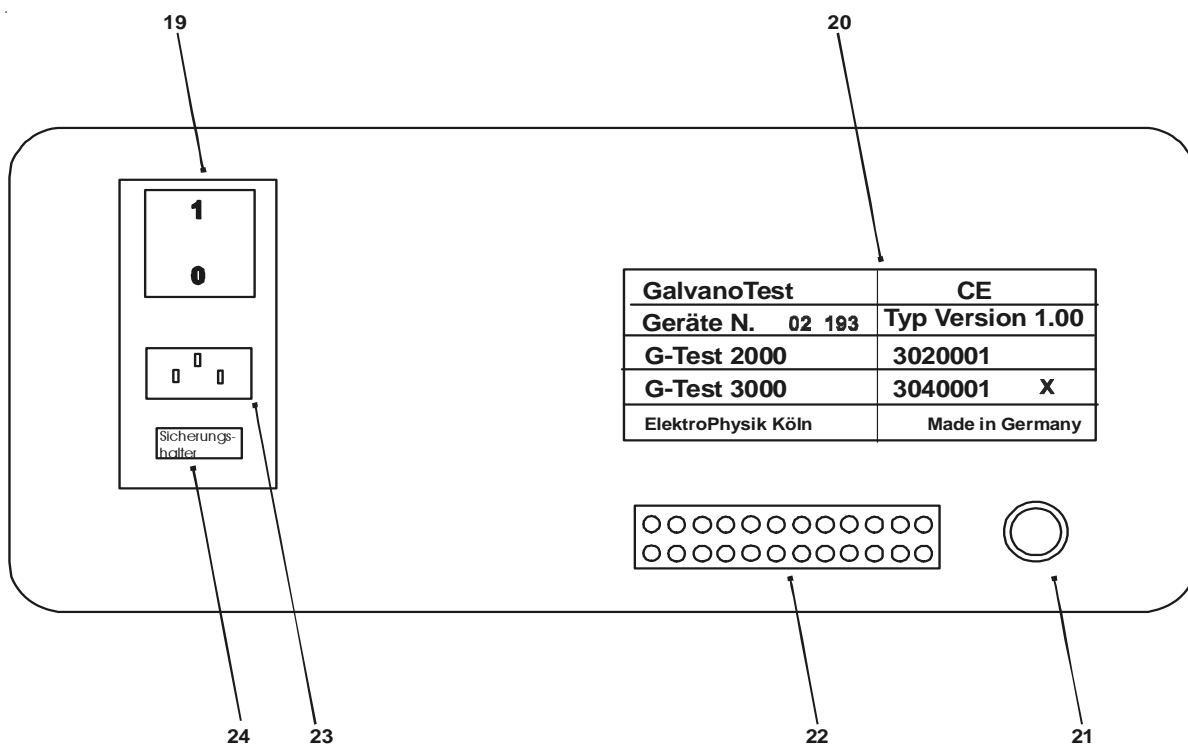
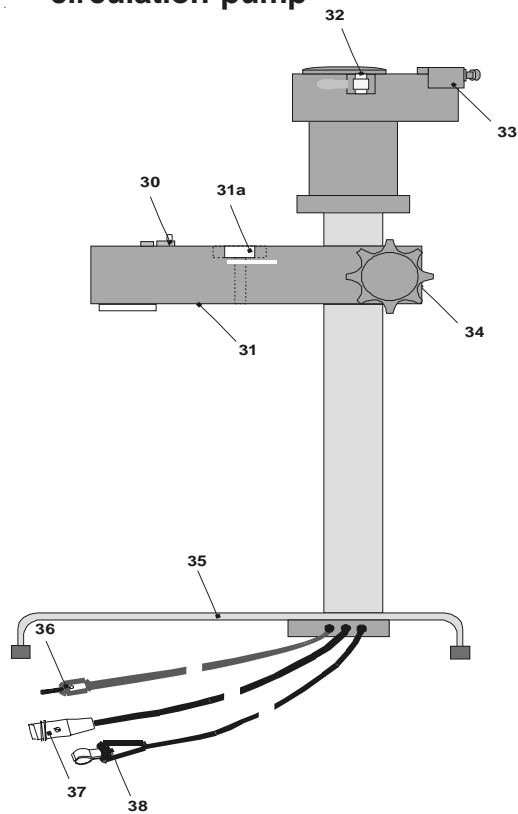

Fig. 2

1	analog meter for monitoring test voltage at measuring cell	6	SET-key: for setting parameters selected by ARROW-keys
2	4-digit floating point display for showing readings	7	START/STOP-key: for manual launching and stopping measuring process
3	16-digit alphanumerical display	8	THICKNESS/VOLTAGE-key for - switching display to cell voltage view during the measuring process - printing-out voltage curve on MiniPrint 4100 data printer
4	STATS-key for activating statistics	9	PRINT-key for printing out - date and time - readings - statistical values on MiniPrint 4100 data printer
5	ARROW-keys for setting - substrate material - measuring area - de-plating speed - sensitivity - calibration - thickness of coating thickness standard - measuring unit - date and time - language		

<p>10 CLEAR-key for</p> <ul style="list-style-type: none"> - deleting the last reading - setting default de-plating speed, default sensitivity and default calibration - interrupting printing process - for error reset <p>10+ 4 CLEAR + STATS-keys:</p> <ul style="list-style-type: none"> - for deleting current statistics memory <p>11 UNIT: selected measuring unit</p> <p>12 CAL: selected calibration</p> <p>13 SENS: selected sensitivity</p> <p>14 SPEED: selected de-plating speed</p> <p>15 AREA: selected measuring area</p> <p>16 METAL: selected coating material</p>	<p>17 cable socket:</p> <p style="padding-left: 20px;">to connect gauge to measuring stand</p> <p>18 pump-keys:</p> <p style="padding-left: 20px;">for filling or emptying the inner measuring cell</p> <p>19 mains switch</p> <p>20 nameplate</p> <p>21 socket for Y-Twriter</p> <p>22 socket for MiniPrint 4100 data printer or RS 232C</p> <p>23 power socket</p> <p>24 fuse holder with supply voltage control 220V/50Hz or 110V/60Hz</p> <p>Switching from 220V to 110V:</p> <p>Remove fuse holder (24), turn 180 degrees and put in place again.</p>
---	--

1.3 Measuring stand with integrated circulation pump



- 30 pressure device: to ensure constant contact pressure on the measuring cell
- 31 measuring cell holder
- 31a recess: to ensure a fixed position of the electrolyte bottles when filling the inner measuring cell
- 32 circulation pump: to ensure a steady circulation of the electrolyte solution during measurement
- 33 adjusting screw: to adjust circulation (Important note: Please do not change factory setting!)
- 34 stopper of measuring cell holder (vertical adjustment)
- 35 working surface: for positioning the measuring sample
- 36 cathode plug: to be connected to the outer measuring cell (42a)
- 37 cable: to be connected to the cable socket (17)
- 38 clamp: to be fixed to the measuring sample

Fig. 3

Suction hose: to be connected to the circulation pump (32)

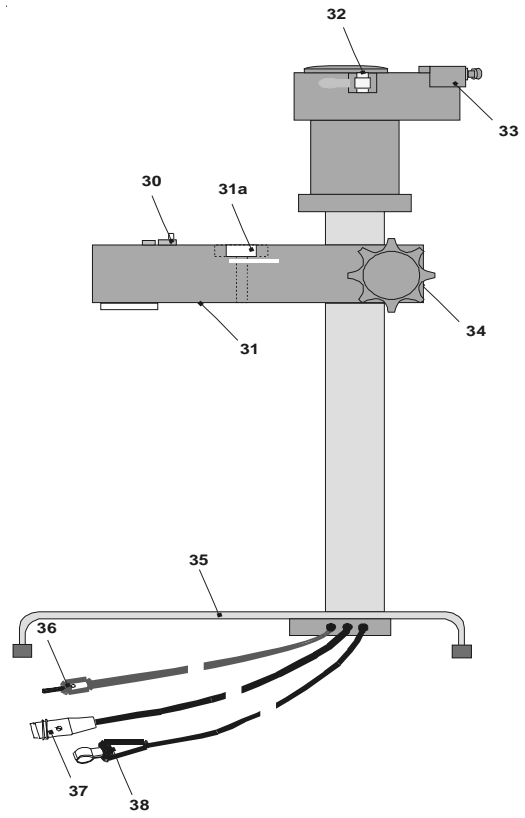
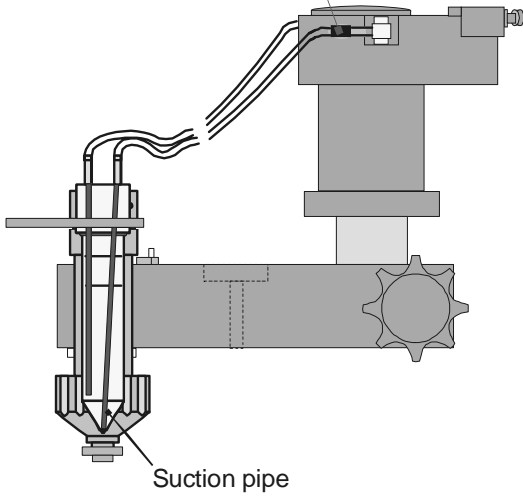
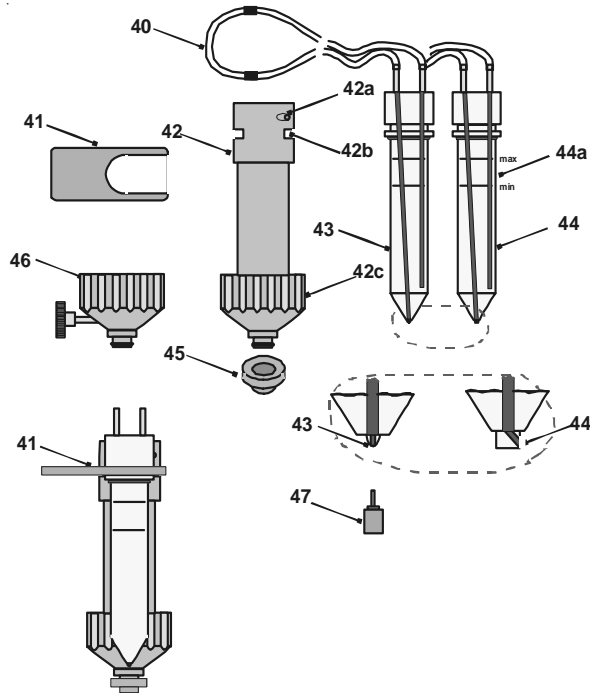

Fig. 3a

1.4 Measuring cell 3000 and fasteners



40 pump tube

Fig. 4

- 41 clamping fork: for sealing the inner measuring cell
- 42 outer measuring cell: holds the inner measuring cell
- 42a bore hole: current supply point
- 42b nut for clamping fork
- 42c rubber gasket holder: may be replaced by the wire holder (46)
- 43 inner measuring cell, type I: to be filled with the electrolyte solution (vertical drain of solution)
- 44 inner measuring cell, type II: to be filled with the electrolyte solution (diagonal drain of solution, see Electrolyte solution selection table)
- 44a Max/Min marking: limit for electrolyte solution
- 45 Circular rubber gasket: to delimit and seal the measuring area (prevents electrolyte solution drain off)
- 46 wire holder: for measuring wires in the electrolyte cup
- 47 sealing device for inner measuring cell

2. Introduction

2.1 General Usage and measuring principle

The coulometric or electrochemical de-plating technique according to DIN 50955 / ISO 2177 is suitable for the measurement of electroplated coatings on practically all substrate materials, i.e.: on steel, on non-ferrous metals and also on insulating materials, e.g. nickel on steel, zinc on steel, tin on copper, silver on copper and copper on epoxy.

This method is also suitable for measuring the individual coatings of multi-layer systems such as chrome on nickel on copper on steel.

The measuring principle is based on Faraday's Law. The opposite of the electroplating method applies, the coating being electro-chemically removed from the sample.

On this purpose, a stainless steel measuring cell is placed on the sample to be measured. The cell is filled with an electrolyte solution which is selected according to the coating / base combination. A rubber gasket placed between the cell and the sample defines the area of measurement, e.g. 4 sq. mm. The measuring set-up is electrically connected to the electronic processing unit.

When switched on, a constant current flows through the electrolyte to remove the metallic coating electro-chemically.

Throughout the entire de-plating process, a defined voltage can be observed between measuring cell and object to be measured. As soon as the metallic coating has been completely removed, a characteristic voltage jump occurs. This voltage jump is registered by the measuring gauge to interrupt the voltage supply and to stop the timer. Thickness is immediately displayed in mils or microns.

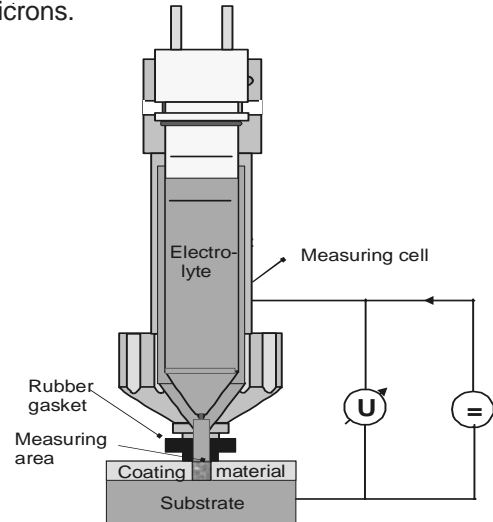

Typical voltage curve

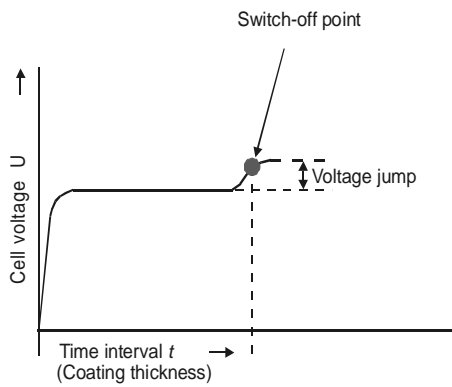

V: de-plating volume

$$V = \text{Measuring area} \times \text{Coating Thickness} \approx \text{Time interval} \times \text{Current}$$

$$\text{Coating thickness} \approx \text{Time interval}$$

2.2 Description

GalvanoTest 3000 includes 10 different metal selections which are preset: chrome, nickel, Copper, brass, zinc, silver, tin, lead, cadmium and gold. Zinn, Blei, Kadmium und Gold.

In addition, 8 user-definable metal memories (M1....M8) are available. The instrument can be used with three defined measuring areas of different sizes. In addition, the electrolyte cup allows to measure a variable measuring size (*K*).

rubber gasket	Nr. B	4,00 mm ² (∅ 2,26 mm)
mask	Nr. C	1,00 mm ² (∅ 1,13 mm)
mask	Nr. D	0,25 mm ² (∅ 0,56 mm)
electrolyte cup	K	for small parts and wires

The de-plating speed is adjustable in a wide range from 0,3 to 40 μm/min.

The readings may be processed in the statistics program. The portable data printer MiniPrint 4100 provides data print-outs including all single readings and up to 6 statistical values including date and time of print-out (quartz controlled time clock).

Special feature: individual print-out of single measurements together with their characteristic voltage curves and switch-off points on the data printer MiniTest 4100.

The instruments allows storage of settings such as calibration or statistics which preset the unit when recalled.

Any operating error will be shown on the alpha-numerical display in English, German or French (operator selectable).

Equipped with an RS 232 C interface, the instrument can be linked to an IBM PC or any compatible computer or printer.

3. Supply schedule

3.1 Standard supply

- GalvanoTest 3000 processing unit
- interface for MiniPrint 4100 data printer or PC
- socket for Y-T-writer
- measuring stand 3000 with integrated circulation pump
- outer measuring cell and inner measuring cell, type I
- sealing device
- 2 rubber gaskets *B* (4,00 mm²)
- 2 rubber gaskets (\varnothing 1,5mm) for sealing the masks
- 20 masks *C* (1,00 mm²)
- 20 masks *D* (0,25 mm²)
- rubber pencil
- pipette
- 5 x100 ml electrolyte solution, assorted to customer requirements
- 1 bottle for used electrolyte solution, 100 ml
- 1 washing bottle, 100 ml
- 1 package absorbant paper
- operating instructions including works certificate

3.2 Recommended accessories

- inner measuring cell type I or II, for working with a second electrolyte solution
- sealing device
- positioning arm
- spare pump tube
- electrolyte cup incl. connecting cable
- wire holder for measuring wires
- small parts holder
- bottle stand for holding up to 7 electrolyte solution bottles, 100 ml each
- coating thickness standards (s.also section 4.2.3, index ST)
- electrolyte selection
- spare rubber pencil
- centering device (Z2)
- measuring cell stand for holding up to 5 inner measuring cells
- spare pipette
- spare rubber gaskets *B* (4,00 mm²)
- masks *C* (1,00 mm²)
- masks *D* (0,25 mm²)
- modified rubber gasket *D/Au* (0,25 mm²)
- external accu battery powered data printer MiniPrint 4100
- connecting cable for MiniPrint 4100 data printer
- connecting cable for Y-T-writer
- RS 232 connecting cable for PC or printer
- MSoft7000 data transfer program

4. Taking Readings

4.1 Adjusting the instrument

Before starting operation select supply voltage with the voltage control switch (24). After switching on, the analogue meter (1) lights up. The previous setting is shown on the alpha-numerica display (3), e.g.:

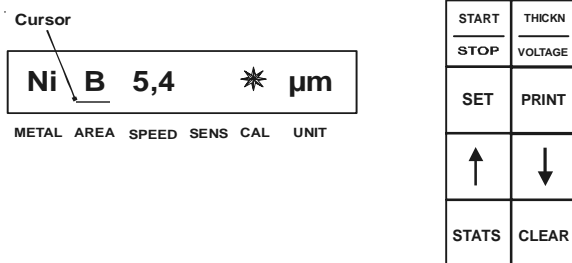

The instrument can be adjusted by pressing SET (6) and ARROW-(5) keys. For setting into selection mode, press SET-key. The position of the red cursor on the alpha-numerical display indicates the parameter which is to be set (e.g. de-plating speed or metal selection). Use the ARROW-keys for setting the required parameter. The parameters set by the ARROW-keys will be directly accepted. For quick setting, keep SET- or ARROW-key pressed down continuously (Quick function).

4.1.1 Metal coating material (METAL)

Position the cursor to METAL (16) by pressing SET-key. Use the ARROW-keys for setting your metal selection. The options are shown in the following order:

Cr, Ni, Cu, Ms (brass), Zn, Ag, Sn, Pb, Cd, Au.

A set of further 8 metal memories (M1...M9) is free-programmable.

4.1.2 Measuring area (AREA)

Position the cursor to AREA (15) by pressing SET-key. Use the ARROW-keys for setting the required area (*B*, *C* or *K*). The size of your measuring area selection is shown on the reading display (2) while the corresponding unit is displayed on the alpha-numerical display (3) in sq. mm or thousands of sq. inch. The measuring area *K* is only selectable in combination with the electrolyte cup (see section 7 „Electrolyte cup“).

Note:

Another measuring area can only be selected if there are no data stored in the statistics memory. Otherwise, the following message will appear: “Memory overcharged” (see section 12.5 „Deleting a measuring series incl. statistics“).

4.1.3 Deplating speed control (SPEED)

Position the cursor to SPEED (14) by pressing SET-key and use ARROW-keys for your de-plating speed selection. The de-plating speed is indicated in steps of 50% (ARROW-DOWN-key) or 100% (ARROW-UP key).

In general, the de-plating speed should be selected so that a measuring time between one and three minutes can always be ensured.

The de-plating speed ranges between 0.3 microns/min at minimum and 40 microns/min at maximum. When trying to set higher or lower, the message "MAXIMUM" or "MINIMUM" appears.

The de-plating speed indication on the reading display (2) is more accurate than on the alpha-numerical display (3). The corresponding measuring unit microns or mils are displayed on the alpha-numerical display.

To reset to default de-plating speed press CLEAR-key (10). This default value depends on the metal selection.

Note:

The de-plating speed also depends on the range of source of electricity powering the instruments.

For special applications the de-plating speed is limited. The de-plating speed for Chrome in combination with the measuring area *B*, for instance, must not exceed 40 microns/min. The message "MAXIMUM" may occur. In this case it is recommended to increase the time of measurement accordingly.

4.1.4 Sensitivity (SENS)

Position the cursor to SENS (13) by pressing SET-key. The current sensitivity is shown on the reading display (2) and the voltage being displayed alphanumerically.

Use the ARROW-keys for sensitivity control. Press CLEAR-key to reset to default sensitivity selection.

If the required sensitivity is equal to the default sensitivity, there will be an empty space above the cursor.

Ni	B	5,4	___	*	µm
METAL	AREA	SPEED	SENS	CAL	UNIT

If the required sensitivity is different from the default sensitivity an asterisk will be displayed above the cursor.



For more information on sensitivity setting please refer to section 10 „Sensitivity“.

4.1.5 Calibration (CAL)

Press SET-key for positioning the cursor to CAL (12). The current calibration (factor) is displayed on the reading display while on the alpha-numerical display a crossbar is shown on the position for “unit”, i.e. the calibration factor is indicated without unit.

Use ARROW-keys for setting calibration or select default calibration by pressing CLEAR-key.

If the required calibration factor is equal to the default calibration (factor 1,000), there will be an empty space above the cursor and 1,000 for default value can be read.

If you have selected a calibration factor other than 1,000, an asterisk (*) appears on the alphanumeric display. For more information on calibration please refer to section 9 „Calibration“.

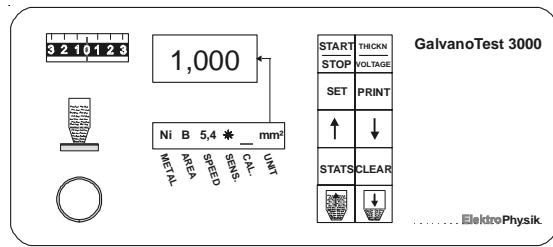

4.1.6 Measuring unit (UNIT)

Press SET-key for positioning the cursor to UNIT (11). Use ARROW-keys for selecting metric (microns) or American mode (mils).

If you press SET-key again, the cursor disappears. For resetting the cursor to the first position (METAL) and repeating the whole setting procedure, press SET once more.

4.2 Preparing measurement

4.2.1 Cleaning the sample

The surface of the sample should be free of grease, lacquer, oxide or passivation films. Use ordinary solvent for cleaning. Oxide films can be removed by means of alcohol or by means of the rubber pencil supplied with the instrument.

Use ElektroPhysik PE 1 solution (accessories) or the rubber pencil for removing chromate coatings on zinc (see also paragraph 8.5 "Chromed zinc coatings").

4.2.2 Positioning the sample

The sample should be placed on the working surface (35) in a stable position. Make sure that the measuring cell can sit at right angles to the sample. If necessary, the small part holder can be used (section 6).

Place an appropriate rubber gasket (45) onto the outer measuring cell (42). i.e. rubber gasket *B* (4 mm²) or the rubber gasket with \varnothing 1,5mm if you use the mask *C* (1 mm²) or *D* (0,25 mm²).

Note:

To prevent erratic readings, the rubber gasket \varnothing 1,5 mm should **never be used without mask**. The rubber gasket has an area of 1,8 mm².

Release the stopper (34) at the measuring stand and place the measuring cell onto the measuring sample.

Push the measuring cell holder (31) down until the distance piece of the pressuer device (30) locks into place.

Tighten the stopper (34).

Release the distance piece.

The built-in springs now exert a constant pressure of the measuring cell on the sample. It is thus guaranteed that the rubber gasket always keeps the same shape and therefore the same measuring area. This is especially important when using the rubber gasket *B* (4 mm²)!

4.2.3 Elektrolyt selection table

Coating Substrate	Silver (Ag)	Gold (Au)	Cadmium (Cd)	Chrome (Cr)	Copper (Cu)	Brass (Ms)	Nickel (Ni)	Current-less Nickel	Lead (Pb)	Lead / Tin	Tin (Sn)	Tin/ Zinc ⁴	Zinc (Zn)
Non metal	E 4	E 1:8	E 5	E 11	E 4	E 4	E 14	E 17 ⁸	E 15 ⁸	E 4 ⁸	E 7	E 7 ⁸	E 6
Silver									E 15 ⁸				
Aluminium	E 4 ⁸		E 5 ⁸	E 11 ⁸	E 4 ⁸	E 4 ⁸	E 14 ⁸	E 17 ⁸	E 15 ⁸	E 4 ⁸	E 11 ⁸		E 6 ⁸
Bronze	E 8 ⁸										E 7 ⁸		
Cadmium											E 7 ⁸		
Copper	E 8 ST	E 1:8	E 5 ST	E 7 ST			E 14 ST		E 15	E 4 ⁸	E 9 ^{5;ST}	E 7 ^{4:8}	E 6 ^{8;ST}
Steel	E 4 ST	E 1:8	E 5 ST	E 11 ST	E 4 ST	E 4	E 14 ST	E 17	E 15	E 4 ⁸	E 7 ^{8;ST}	E 7 ^{4:8}	E 20 ^{8;ST}
Brass	E 8 ST	E 1:8	E 5 ST	E 7 ST	E 12	*8	E 14 ST		E 15	E 4 ⁸	E 9 ^{3;5;8;ST}	E 7 ^{4:8}	E 6 ^{8;8;ST}
Nickel	E 4 ⁸	E 1:8	E 5 ⁸	E 11 ST	E 4 ⁸	E 4 ⁸			E 15 ⁸		E 7 ⁸		E 6 ⁸
Silicon							E 14 ⁸						
Zinc					E 12 ^{ST,2;8}								
Kovar					E 4 ⁸				E 15 ⁸				
Argentan silver	E 8 ⁸			E 7 ⁸								E 7 ⁸	
Zinc diecasting					E 12 ⁸								

¹⁾ For electrolyte selection and instrument adjustment please refer to our customer support

²⁾ see section 8.9 „Copper on Zinc“

³⁾ see section 8.10 „Tin on Brass“

⁴⁾ for Tin/Zinc 78%/22%

⁵⁾ Please use the inner measuring cell type II.

⁸⁾ Requires careful measurement. Please contact our customer support if necessary.

^{ST)} Coating thickness standards available on stock

4.2.4 Choosing electrolyte and measuring cell

Choose an appropriate electrolyte solution and measuring cell according to the selection table. For standard applications, the measuring cell type I should be used. If however, your electrolyte solution shows an index⁵ (e.g. E⁵ for Cadmium on non-ferrous metals), the inner measuring cell type II is to be used.

4.2.5 Filling in the electrolyte solution

Dip the inner measuring cell into the electrolyte bottle and press the Pump-UP-key (18). Keep pressed down until the electrolyte reaches the limits of the Max/Min marking (44a). Place the inner measuring cell into the outer one and seal it by means of the clamping fork (41). Now measurement can start.

4.3 Taking readings

Press START-key. The launch of measuring procedure is indicated by analogue meter (1) deflection. After that, the needle returns to zero position. Deviations up to +/- 0.5 can be ignored.

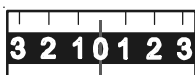

The reading display (2) continuously shows the coating thickness being removed.

During measuring, it can be switched from thickness to cell voltage by pressing THICKNESS/VOLTAGE-key (8) with the corresponding unit (microns/mils or Volts, respectively) being shown on the alpha-numerical display (3).

Shortly before the measurement being finished, a slow analogue meter (1) deflection to the right can be observed indicating the start of the voltage jump. A few seconds later, the instrument cuts off the measuring current and emits an audible signal. At the same time, the continuous reading display (2) stops and displays the de-plated coating thickness in microns or mils.

If you have switched to VOLTAGE display (measuring cell voltage), the instrument switches automatically to coating thickness at the end of measurement.

The readings are automatically stored in the statistics memory and, if the printer is connected, printed-out along with their current identification number.

If the reading is not to be stored in the statistics, press CLEAR-key (10) for deletion. Deletion is confirmed by the printed message *CANCEL*.

After completion of measurement, press THICKNESS/VOLTAGE-key (8) for recalling the last voltage setting at the measuring cell.

Measurement can be interrupted manually by pressing the STOP-key (7). If measurement is interrupted later than 3 seconds after being started, the measurement is valid and the reading will be processed as usual (automatic stop).

4.4 After measurement

If a further measurement is to be taken for the same coating/substrate combination, lift the measuring cell (42) and remove the measuring sample. Clean with a soft paper towel. Then proceed according to section 4.3.

If it is necessary to change the electrolyte solution (e.g. for measuring another coating/substrate combination or if the electrolyte solution is saturated), another inner measuring cell (43/44) should be used. Pump the saturated electrolyte solution into the bottle for used solution. Remove the inner measuring cell and press the PUMP-DOWN (18) key for emptying.

Note:

Do not mix up used solutions with fresh ones! Before you continue to work with another solution, please carefully rinse the outer and inner measuring cells with distilled water.

After measurement, the depleted measuring area should be inspected carefully. It should be round and evenly de-plated.

4.4.1 Electrolyte saturation

The measuring cell is designed to carry out several measurements subsequently without the need to change the electrolyte solution. As soon as the electrolyte solution has been saturated, the alphanumeric display (3) will show „*Electrolyte saturated*“. In this case, you should replace the solution by a fresh one.

The message „Electrolyte“ means that the electrolyte solution will be saturated within a short time.

The following table shows the different de-plating volumes at which the relevant electrolyte solutions will be saturated.

Metal	Cr	Ni	Cu	Ms	Zn	Ag	Sn	Pb	Cd	Au
De-plating volume in $\mu\text{m}/\text{mm}^2$	300	300	300	300	150	300	300	150	150	100
Free programmable metal memory	M1	M2	M3	M4	M5	M6	M7	M8		
De-plating volume in $\mu\text{m}/\text{mm}^2$	300	300	300	300	300	300	300	300		

Example:

For chrome, the electrolyte saturation point is reached as soon as a volume of $300 \mu\text{m}/\text{mm}^2$ chrome has been de-plated.

4.4.2 Y-T writer output

During measurement, the cell voltage can be taken at the Y-Twriter output (21) and displayed in the form of a voltage curve relating to measuring time. This provides supplementary information on the measuring process especially regarding diffusion coatings.

If the Y-Twriter is switched on, a current flow can be observed for a period of about 1/16 of the measuring time, providing the measuring process has been stopped automatically (not manually). Thus the voltage curve can be monitored even after completion of the de-plating process.

4.5 Printing out readings

4.5.1 Print-out of voltage curve

The data printer MiniPrint 4100 allows immediate print-out of voltage curve after the measuring process.

Optimum scalling and print-out of both, readings and voltage values, can be automatically obtained by pressing THICKNESS/VOLTAGE-(8) key. (Keep on pressing more than one second after measurement).

If you press THICKNESS/VOLTAGE-key during measurement, the measuring current will continue to flow for a period of about 1/16 of the measuring time, ensuring that the voltage curve can be monitored also after completion of the de-plating process.

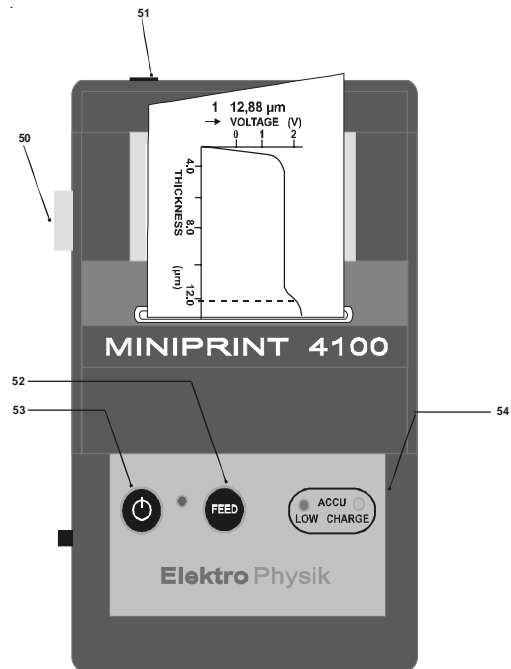

- 50 interface for connecting printer to GalvanoTest 3000
- 51 bush for charging unit
- 52 paper FEED
- 53 ON/OFF-key
- 54 charging control lamp

4.5.2 Readings and statistics

If the MiniPrint 4100 data printer is connected during measurement the readings are printed out after each measurement. The statistical values are printed out individually after completion of the measuring series when pressing STATS-key (4).

If you switch on the printer after completion of a measuring series, you can actuate the complete print-out by pressing PRINT-key (9).

0001	0,96µm] Single readings
0002	1,08µm	
0003	1,72µm	
0004	1,18µm	
0005	1,40µm	
MEAN	1,27µm] Statistics calculated from above single readings
S.D.	0,30µm	
Kvar	0,24	
N	5	
MAX	1,72µm	
MIN	0,96µm	

ElektroPhysik		
STATS. Program		
02-SEP-02	08:27	
Metal	Cr	□ Type of metal coating
Area	B	□ Measuring area
0001	0,96µm] Single readings
0002	1,08µm	
0003	1,72µm	
0004	1,18µm	
0005	1,40µm	
MEAN	1,27µm	□ Mean value
S.D.	0,30µm	□ Standard deviation
Kvar	0,24	□ Variation coefficient
N	5	□ Number of readings
MAX	1,72µm	□ Maximum reading
MIN	0,96µm	□ Minimum reading

5. Measuring stand and accessories

The measuring stand is included in the standard delivery schedule of GalvanoTest 3000. The numbered parts are available as optional accessories.

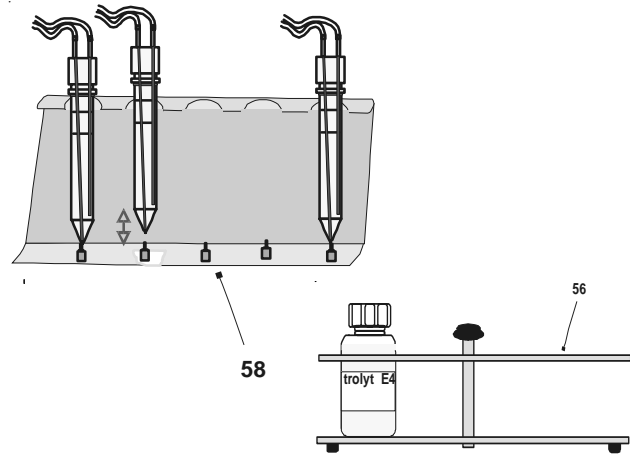
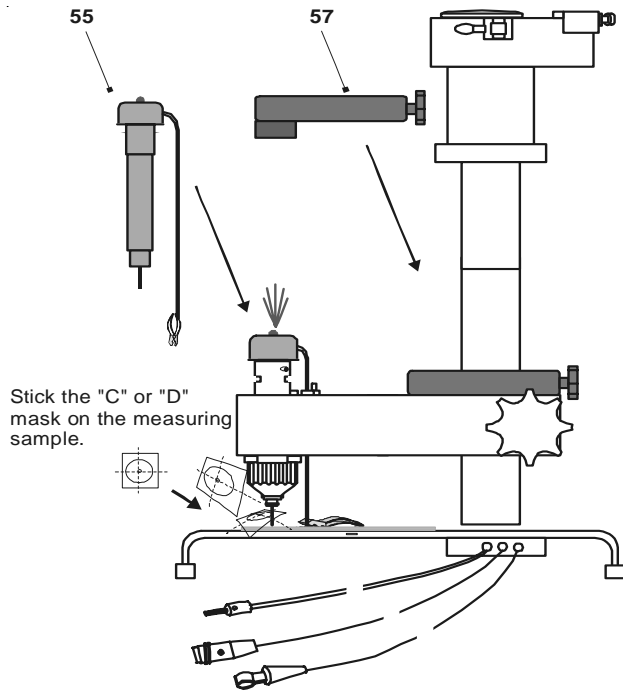

- 55 centering device for pin-point positioning of the measuring cell when using the *C* mask (1,00 mm²) or *D* mask (0,25mm²)
- 56 bottle holder for holding up to 7 electrolyte bottles (100 ml)
- 57 positioning arm, serves as stopper for the measuring cell holder (34)
- 58 measuring cells stand for holding up to 5 inner measuring cells, type I or II, according to customer requirements

5.1 Centering device

The centering tool (55) is used when, because of the shape of the sample, a *C* mask (1mm²) or *D* (0,25 mm²) mask in combination with the rubber gasket (∅ 1,5mm) for sealing the mask is required.

- Clean the sample and stick the mask to the required measuring spot. Place the centering device into the outer measuring cell (42) and push it down to the stop. Then connect the current supply cable to the sample.
- Center the measuring stand so that the pin of the centering device slightly gets into contact with the punch out of the mask. As soon as you've got the right position, the LED at the centering device lights up.
- Place the measuring cell upon the sample (see section 4.2.2) and remove the centering device.
- For more information on the use of the centering device in connection with the modified rubber gasket *D*/Au please refer to section 8.3.

The centering device is powered by a 6Volts battery, type 4LR44. To replace the battery, please loosen the two hexagon sockets on the top of the centering device. Remove the lid, change battery, close lid and fix the screws again.

5.2 Positioning arm

The positioning arm (57) is used in connection with the measuring stand. It serves as stopper for the measuring cell holder ensuring a constant position of the measuring cell. The positioning arm can also be used in connection with the small parts holder (see section 6) or the electrolyte cup (section 7).

6. Small parts holder

For measuring small and irregularly shaped samples. The small parts holder is available as an option.

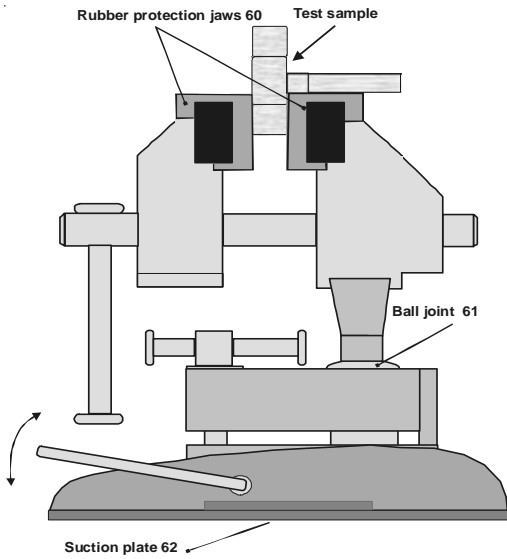

- 60 rubber protection jaws
- 61 ball joint for positioning the test sample
- 62 suction plate for ensuring stable position of the small parts holder during measuring

7. Electrolyte cup

The electrolyte cup is suitable for measurement of wires and small parts. This method is also a time/voltage measurement.

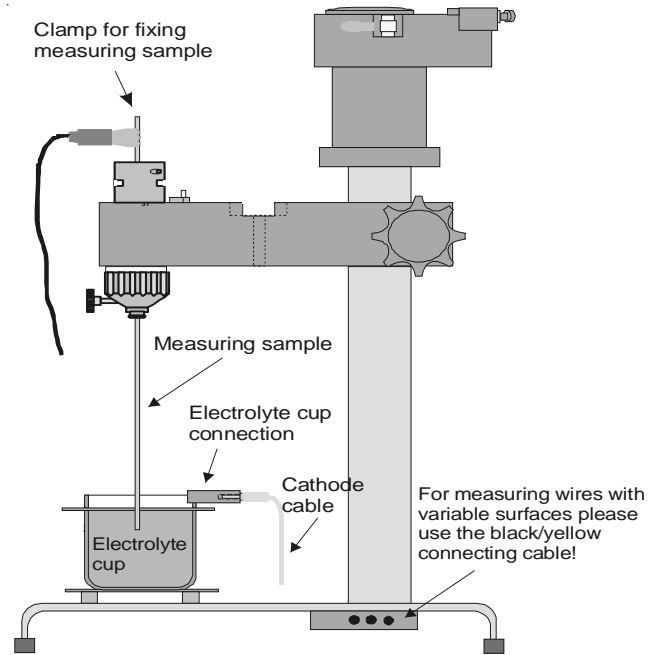

7.1 Variable measuring area

For small parts and wires $\geq \varnothing 0,3$ mm

While the deplating area with the rubber gasket or a mask is always clearly defined by the size of the gasket, the electrolyte-cup-procedure requires a calculation to be made in order to determine the de-plating area. GalvanoTest 3000 allows de-plating areas to be adjusted from 0,25...16 mm².

- Choose the appropriate solution according to the electrolyte selection table (section 4.2.3) and fill the cup to about up to 1 cm from the rim.
- Areas of samples which are not be measured or the ends of wires have to be insulated by lacquer, for instance.

Note:

Use the black and yellow connecting cable for measurements with the cup!

- Adjust measuring area to „K“. Use the wire holder (46) instead of the rubber gasket holder (42c) (see. Fig. 4). Make further adjustments according to section 4.

- Dip the sample into the electrolyte cup ensuring that the area dipped into the cup approximately corresponds to your setting of measuring area.
- Adjust the electrolyte cup holder so that the sample is in the middle of the cup. The sample must not touch the cup at any point, even on the bottom.
- Fit the cathode plug into the socket on the cup and fix the sample clamp to the sample. The contact point must be clean so that a good electrical contact is made.
- The solution can be used for several measurements (20 to 30 depending on the size of the samples), but it should not be left in the cup for a longer time, but removed and stored in a suitable bottle. Do not refill into the bottle with new solution!
- Press START/STOP-key. The following message is shown on the alphanumeric display: „Measuring area?“. Use ARROW-keys for setting the approximate measuring area.

- Press START/STOP-key or SET-key for starting measurement. At the end of the measuring procedure, the alphanumerical display shows again „Measuring area?“.
- Use the ARROW-keys for setting the precise deplating area (which has been calculated beforehand) and confirm by pressing SET-key. The instrument now calculates, displays and stores the thickness value of the coating.

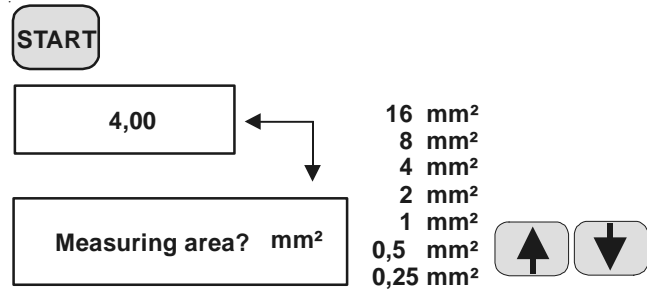

Note:

Depending on the type and thickness of coating, wires $\leq \varnothing 0,3$ mm may also be measured in the electrolyte cup.

Example for measuring wires by means of the electrolyte cup:

- Press START-key and use ARROW-keys for setting the measuring area according to wire diameter and depth of immersion.

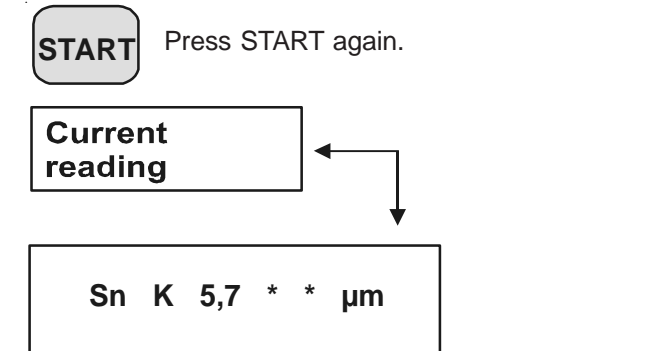

Remove wire after completion of measurement.

- After this, use a caliper to measure diameter and length of the de-plated wire area.

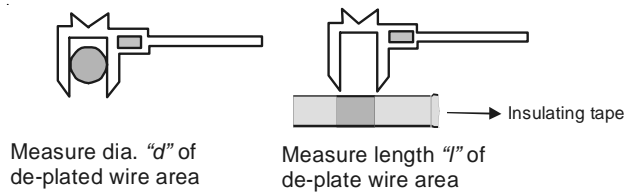

- Use the measured wire dia. „d“ and the length „l“ of the de-plated wire area to determine the actual deplated wire area as follows:

$$F = d \times \pi \times l$$

F = Area

d = Diameter of wire

$\pi = 3,14$

l = length of de-plated area

- Use ARROW-keys for setting the actual measuring area, e.g. 5,36 mm².
- Press SET-key to show the reading as calculated by means of the actual measuring area, e.g. : 7,4

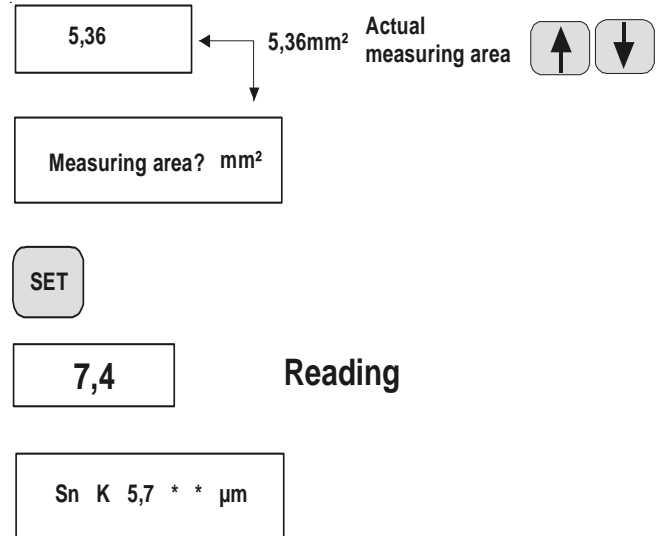

7.2 "C" Mask

The C mask is suitable for measuring wires of $\varnothing \geq 2$ mm and should be used in combination with the red/black connecting cable.

- Stick the mask onto the wire ensuring to insulate the end of wire completely. If necessary, use lacquer. Dip the wire into the electrolyte cup ensuring that the punched hole of the C mask is completely immersed into the solution.
- Continue as described under section 4. "Taking readings".
- As soon as the instrument switches off automatically, the reading can be read from display. There is no need to calculate the measuring area.

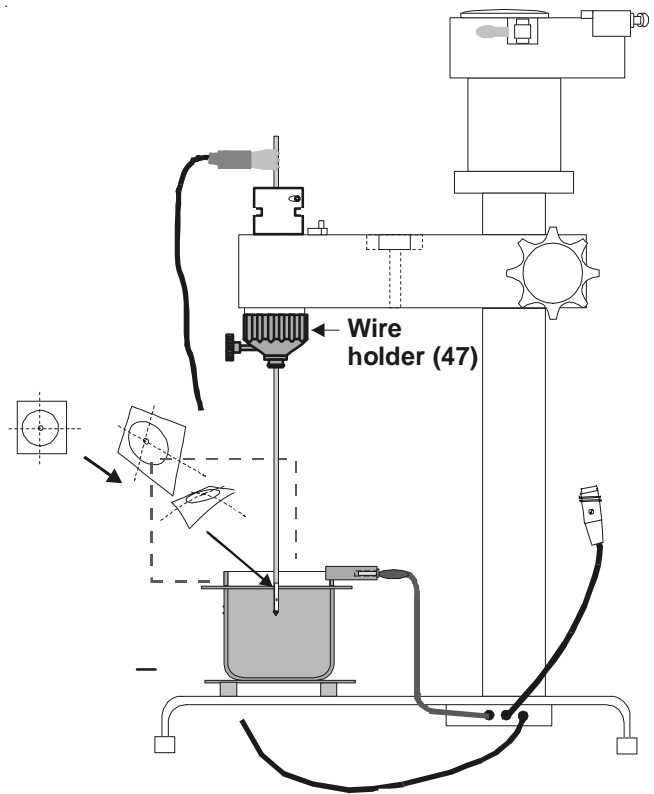
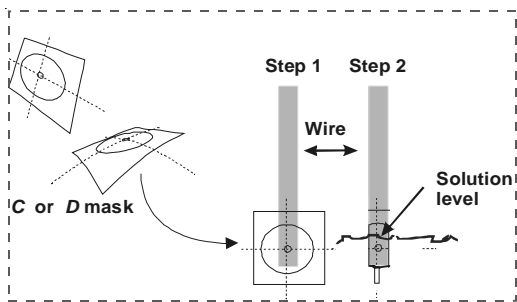

8. Special applications

8.1 Convex surfaces

For convex surfaces please use the following items:

Samples $\varnothing \geq 8\text{mm}$:

rubber gasket *B*

Samples $\varnothing \geq 6\text{mm}$:

rubber gasket $\varnothing 1,5\text{mm}$ and *C* mask or

rubber gasket $\varnothing 1,5\text{mm}$ and *D* mask

Samples $\varnothing < 6\text{mm}$:

under certain circumstances measurable with the electrolyte cup

Samples $\varnothing \geq 4\text{mm}$:

rubber gasket $\varnothing 1,5\text{m}$ (can be **adapted** to the diameter of sample) in combination with the *C* or *D* mask

Use abrasive paper to adapt the circular gasket to the shape of sample.

Samples $\varnothing < 4\text{mm}$ (e.g. wires):

electrolyte cup

Wires $\varnothing \geq 2\text{mm}$:

electrolyte cup and mask

Wires $\varnothing \leq 0,3\text{mm}$:

depending on the type and thickness of coating measurable in the electrolyte cup in combination with a mask.

Adapting the rubber gasket to the shape of sample:

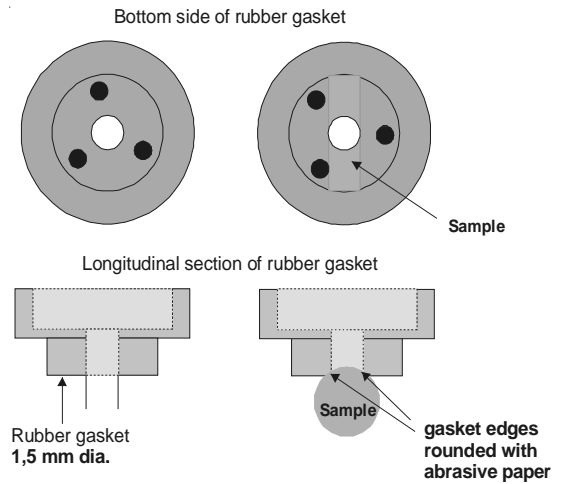

The rubber gasket *B* should not be adapted to the diameter of sample as this would change its defined measuring area.

8.2 Concave surfaces

Samples $\varnothing \geq 100\text{mm}$:

rubber gasket $\varnothing 1,5\text{mm}$ and C or D mask

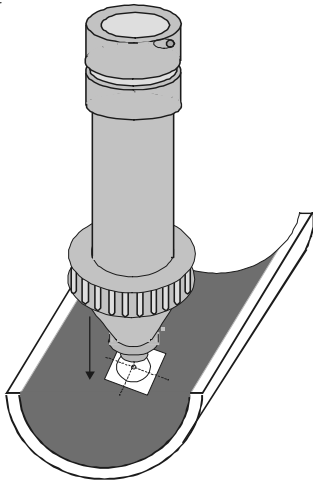

Note:

Only samples accessible from the upper side can be measured.

8.3 Gold coatings (Au)

Gold coatings can be measured by means of the modified rubber gasket *D/Au* ($0,25\text{mm}^2$). Being resistant to electrolyte solutions, this gasket enables measurement of gold (Au) on smooth and even surfaces.

Its size of measuring area is the same as with the mask *D* ($0,25\text{mm}^2$). When using the modified rubber gasket *D/Au* on the measuring stand, full contact pressure must be applied to ensure maximum sealing of the mask on the measuring surface.

The *D* and *C* masks are not suitable for measuring gold. For larger measuring areas, you can use the rubber gasket *B*.

8.4 Multi-layer coatings

The GalvanoTest 3000 is suitable for measuring subsequently the individual coatings of multi-layer systems (such as chrome, nickel, copper on steel) at one measuring point. There is no need to lift the measuring cell between the individual measurements.

Measurement of the upper layer is carried out according to the general instructions of section 4.

- After measurement switches off, cautiously remove the inner measuring cell making sure not to change the position of the outer measuring cell on the sample.
- Pump the used electrolyte solution into a separate bottle.
- Rinse the inner and outer measuring cells twice using distilled water.
- Move the cursor under METAL on the alphanumeric display (3) to adjust the next material to be measured.
- Fill fresh electrolyte solution into the inner measuring cell and launch measurement for the next smaller measuring area.

Notes:

To ensure optimum use of the electrolyte and maximum ease of operation it is recommended to use a set of several inner measuring cells.

In general it is not necessary to lift the measuring cell from the sample between the individual measurements. If, however, electrically insulating material has built-up on the sample it is necessary to lift the measuring cell in order to remove such deposits.

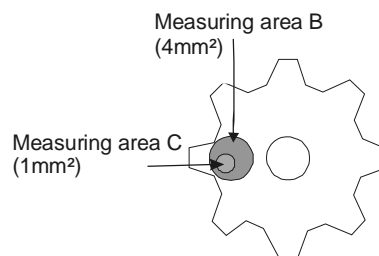

8.5 Chromed zinc coatings

Before placing the measuring cell, remove any passivation layers that may have built-up on the sample.

This is done best with a rubber pencil or with ElektroPhysik solution PE1.

Put some solution in the measuring cell and leave for a few seconds. Then pump out the PE1 solution, rinse the measuring cell with distilled water and proceed as described under section 4.2.

8.6 Diffusion layers

Some metals tend to penetrate into the surface of the next layer. For that reason, the instrument may switch-off after de-plating the pure metal layer e.g. Sn.

If you examine the measuring area, you cannot see the next metal layer but the metal of the first layer which has penetrated into the layer underneath. In such case, we recommend to decrease sensitivity i.e. to set a higher voltage value.

On the other hand, when measuring extremely distinctive diffusion layers (e.g. Zn), the voltage jump may not be sufficiently strong enough to switch off measurement. In such cases, the voltage curve may return to normal until a new voltage jump occurs after a short while. This voltage jump however may not be quick enough to switch-off measurement. In such case we recommend to increase sensitivity i.e. to set a lower voltage value.

For setting optimum sensitivity, make sure the instrument does not switch off before the second voltage jump (see also section 10 „Sensitivity“).

The print-out of voltage curve on MiniPrint 4100 shows both, thickness of the pure metal as well as the thickness

of the diffusion layer. Please refer also to section 10 “Sensitivity”.

8.7 Currentless nickel

When measuring currentless nickel (chemical nickel), the phosphor content will cause a slowing down of the de-plating process. The delay time as related to the phosphor content can be taken from the following table:

Phosphor content	4%	5%	6%	7%	8%	9%	10%	11%
Correction value	1,11	1,14	1,16	1,19	1,22	1,24	1,26	1,28

For accurate measurement, the calibration factor has to be determined according to section 9.2 „Calibrating by means of a factor“ and then divided by the appropriate correction value as specified in the table above.

Note:

The correction values as specified in the above table only apply if calibration has been carried out by means of a nickel standard without phosphor content.

8.8 Nickel on copper on steel

If the instrument does not switch off when using E14 solution for nickel coatings on copper ($\text{Cu} < 2 \mu\text{m}$), it is recommended to use E4 solution. Please note that in this case, the instrument must be calibrated accordingly and that E4 solution removes both layers in one measuring process.

8.9 Copper on zinc

Select „M“ for optional metal selection. It is recommended to adjust the instrument as follows:

De-plating speed:	3...4 $\mu\text{m}/\text{min}$.
Sensitivity:	1,0
Calibration factor:	2-2,1
Solution:	E12

8.10 Tin on brass

Select „M“ for optional metal selection. For $\text{Sn} = 12 \mu\text{m}$, e.g., it is recommended to adjust the instrument as follows:

De-plating speed:	5...6 $\mu\text{m}/\text{min}$
Sensitivity:	2,5
Calibration:	1,7-1,75
Solution:	E9

Note:

The instrument settings under 8.9 and 8.10 are *general* recommendations and may vary according to the individual gauges. For that reason, calibration must be carried out for each GalvanoTest 3000 gauge individually.

8.11 Thick coatings

When measuring thick coatings, the instrument may switch off prematurely i.e. before the coating has been removed completely. In such cases "0.00" will be shown on display and no reading will be stored.

Example:

If you want to measure Cu 50µm at a de-plating speed of 3,14µm/min, the instrument switches off after removing a coating thickness of 31,4µm as maximum de-plating time is 10 minutes:

$$10 \times 3,14\mu\text{m} = 31,4\mu\text{m}$$

In such cases we recommend to carry out measurement in two steps:

- Switch off the instrument manually before automatic switch-off.
- The reading will be stored automatically.
- Restart measurement. As soon as the gauge switches off automatically, both values can be added to give you the total thickness.

9. Calibration

Accurate calibration is most important for successful measurement. Previous calibration values can be overwritten by new ones. Stored readings remain unchanged. New measurement series, however, cannot be stored until previous readings in the statistics have been deleted (see section 12.5 „Deleting a measuring series incl. statistics“).

9.1 Calibrating by means of a coating thickness standards

- Take measurement on the coating thickness standard.
- Press SET-key for positioning the cursor to CAL. A reading is shown with the corresponding unit (microns or mils) shown on the alphanumeric display.
- Use the ARROW-keys for setting the thickness as indicated on the calibration standard. Continuous pressing of ARROW-keys supports quick function. Your setting will be valid without the need of being confirmed.
- If MiniPrint 4100 is connected and switched on, the message *Cancel* will be printed after pressing the ARROW-key.
- The following measurements will be carried out on the basis of your calibration selection.
- For checking purpose, take another measurement on your calibration standard.

9.2 Calibrating by means of a factor

If coating thickness standards are not available, calibration can also be performed by means of a calibration factor, providing instrument settings are known. Calibration by means of a factor is only possible

1. if the cursor is not be seen on the alphanumerical display (3). If necessary, press SET-key to make the cursor disappear.
2. if there is no value indicated on the reading display (2). If necessary, carry out the above step 1 and then press CLEAR-key (10).

Then perform setting as follows:

- Use SET-key to position the cursor to CAL (12). The currently valid factor, e.g. 1.300 is shown. On the alphanumerical display, UNIT (11) will be marked by a bar (see also sectionsl 4.1.5 and 9.1).
- To change the factor use ARROW-keys and make your factor selection, e.g. 1.150. There is no need to confirm the new setting. The following measurements will be automatically made on the basis of the new factor setting.

Note:

If you press CLEAR-key during setting (steps 1 and 2), the factor is reset to Default calibration „1.000“.

9.3 Range of calibration factor

In both methods, calibration by means of coating thickness standards and calibration by means of calibration factors, a special factor is set.

For the preset metal selections (Cr...Cd), the calibration factor can be set from 0.5...2, for optional metal selections "M", it ranges from 0.2...5.

When trying to exceed these ranges, the alphanumerical display will show the following message: "Maximum" or "Minimum".

9.4 Reset to default calibration (1.000)

If for special applications, a factor other than 1.000 has been set (e.g. 1.300), an asterik (*) will appear on CAL position. To reset default calibration please proceed as follows:

- Use the SET-key to position the cursor to CAL .
- Press CLEAR-key. The factor will be reset to 1.000. The asterisk (*) above the cursor will disappear.

Note:

When pressing CLEAR-key, any reading will change according to the current factor selection. Example:

2.6 μm changes to 2.0 μm .

10. Sensitivity (SENS)

The coulometric technique uses a controlled “de-plating” current rate (i.e. the time required to remove the plating material) to determine the thickness of a coating. For that reason, the duration of measurement and its exact switch-off point must be exactly determined (see time-voltage diagram in section 2.1 „General usage and measuring principle“).

Your sensitivity setting determines the switch-off point. If after switch-off the coating has not been completely removed, GalvanoTest 3000 has switched off prematurely and certain spots can be observed on the de-plating area. To ensure a smooth and even de-plating area, it is recommended to increase the test voltage.

E.g. for nickel it is recommended to increase the test voltage from 1.0 (default value) to 1.2 Volts. If the instrument does not switch off in time, the substrate will be etched by the solution. In this case, sensitivity should be decreased (for nickel, e.g., decrease test voltage from 1.0 to 0.8 Volts).

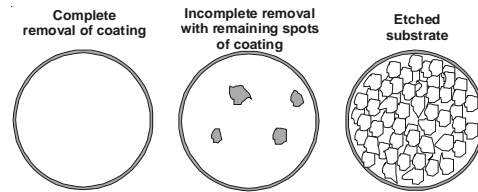

10.1 Reset to default sensitivity

The instrument is factory adjusted so that a certain sensitivity value (Volt) is preset for each different metal selection. When changing sensitivity preset, an asterisk (*) will appear above SENS. For resetting to default sensitivity, please proceed as follows:

- Use SET-key to position the cursor to SENS.
- Press CLEAR-key. The sensitivity value U resets to factory setting (default value). The asterisk (*) above the cursor disappears. The sensitivity value U is shown in Volts on the reading display.

11. Measuring uncertainty

Careful calibration ensures precise measurement within the range of the guaranteed measuring uncertainties (please refer to the technical data).

For optimum mean value evaluation, we recommend to take several measurements at the same spots. Erratic readings can be deleted immediately by pressing CLEAR-key.

11.1 Error sources

- If you **exceed the measuring time** as rated for your application, the de-plating area will increase. As a consequence, measurement will be out of tolerances. For that reason it is recommended not to exceed the provided measuring time interval.
- The **current efficiency variegates** due to different de-plating speeds. We recommend to calibrate at the same de-plating speed as set for later measurement.
- **Impurities or alloy components** in the coating material may lead to erratic readings. If necessary,

carry out comparison measurements according to the cross-cut method.

- The **efficiency of the solution may decrease**. It is recommended to use fresh electrolyte solution.

12. Statistics mode

All readings of a measuring series will be recorded automatically for statistical evaluation. Ten different metal selection memories are available to store 2000 readings in total.

The statistics program is designed to calculate on the basis of at least two readings the following statistical values:

Mean value	(<i>MEAN</i>)
Standard deviation	(<i>S.D.</i>)
Variation coefficient	(<i>Kvar</i>)
Number of readings	(<i>N</i>)
Maximum single reading	(<i>Max</i>)
Minimum single reading	(<i>Min</i>)

12.1 Recording a measuring series and statistics calculation

On switch-on, the instrument is ready for operation. All readings will be stored automatically. Before starting measurement, check if it is necessary to calibrate for your application and/or if the statistics must be deleted (see section 12.5). If you recalibrate the instrument, the old calibration settings will be deleted.

Note:

A measuring series can be recalled and continued after off/on-switching.

12.2 Recalling and print-out of statistics

Press STATS-key as required to display the statistical values subsequently in a row. If the printer is connected, the readings will be printed out (printer ON). The statistical values can be displayed or printed out as often as required and at any time after measurement.

12.3 Print-out of readings and statistics

Press GalvanoTest PRINT-key. If the printer is connected, the following values will be printed out:

- date and time
- all readings
- all statistical values

While printing, the alphanumeric display shows „Printing...“. Press CLEAR-key for print stop if required.

If there is no printer connected or if the printer is switched off, the data can also be transferred via the RS 232 C interface (see section 19).

12.4 Deleting a previous reading

Deletion is only possible directly after the last measurement , i.e. before taking the next one.

- Press CLEAR-key.
- An audible signal confirms deletion. If the printer is connected, the following message will be printed out: *Cancel*.

12.5 Deleting a measuring series incl. statistics

- Make your metal selection - e.g. Ni for nickel
- The cursor should not be seen.
- Press CLEAR-key and keep pressed down, then press STATS-key simultaneously.
- An audible tone sounds and the message „STAT. deleted“ appears for about 2 seconds.

12.6 Exceeding storage capacity

At the beginning of any measurement, the instrument performs an automatic storage capacity check. If maximum capacity is reached, "Full Memory" will be shown. For taking further measurements delete any statistics memory (see section 12.5).

13. Date and Time

GalvanoTest is equipped with a crystal-controlled time clock which includes an integrated leap year control up to the year 2100. The data printer MiniPrint 4100 provides print-outs including current date and time.

Date and time can be recalled or set as follows:

- Press SET-key for about 3 seconds until an audible signal sounds. A certain date and time are shown on the alphanumerical display. The cursor is positioned at the section for "year". Use ARROW-keys for setting the current year.
- Use the SET-key for positioning the cursor to the section for "month". Use ARROW-keys for setting the current month.
- Likewise, day, hour and minutes can be set.
- After completion of your required settings, press SET-key until the cursor disappears from display. Now the currently set date and time are valid.
- Press SET-key for returning to standard operation mode.

14. Language selection

Three operator selectable languages are available:

- German
- English
- French

Make your language selection as follows:

- Switch off the instrument.
- Press both ARROW-keys continuously while you switch the instrument on. The current language selection appears on display, "English" for example.
- Keep both ARROW-keys pressed down and release keys as soon as your required language is shown.
- Your selection is valid without need to confirm.

15. Error messages

Error messages appear on the alphanumerical display.

Maximum	Calibration (CAL), sensitivity (SENS), de-plating speed (SPEED) or measuring area (AREA) have reached maximum value
No cell	No measuring cell connected
No test current	No current flow in the solution. The cause may be: Clamp (38) is not connected to the test sample. Air bubbles on the surface. No solution available in the measuring cell (44). Another solution being in the cell. Surface insulated by grease, paint, or other insulating material. Cell voltage exceeding 10Volts.

Time exceeded	If measurement exceeds 10x the selected de-plating speed, the measuring process will be interrupted automatically and the reading display will show „0,0,“. Measurement is invalid (see section 8.11).
Mem. charged	Appears only if you try to change the measuring area at full statistics memory. Please delete the current statistics memory (see section 12.5) before setting a new measuring area.
Mem. overcharged	Measurement not possible. For further measurements, delete any statistics memory (see 12.5).
No statistics	Error message when trying to call or print any statistics but no data are available in the statistics memory.

16. Further sources of error

Apart from the error sources as described under section 15 which can be identified by their error message, the following errors may occur:

1. The analogue meter and both displays do not light up at switch-on:
 - Check power supply
 - defective fuse
2. Solution leaks:
 - cell not correctly positioned
 - gasket worn or leaks
 - curvature radius of the sample too small
3. Premature switch-off, unsteady meter deflections:
 - poor contact
 - dirty measuring cell
 - air bubbles on the measuring area
 - insufficient solution in the measuring cell
 - gasket leaking
 - sensitivity setting too low
 - dirty measuring surface

-
4. Instrument does not switch off, no analogue meter deflection:
 - unsuitable solution
 - Coating has been removed within the first three seconds, i.e. de-plating speed is too high.
 5. Instrument does not switch off, but clear meter deflection:
 - sensitivity too high
 6. Coating not properly removed:
 - sensitivity too low
 7. Wrong measuring result:
 - check steps 2., 3. and 6. (section 16)
 - instrument misadjusted, no or wrong calibration
 - unsuitable solution
 8. On switch on the instrument does not show any setting, statistics, date and time are deleted:
 - Lithium buffer battery discharge.
Please send the instrument to ElektroPhysik.

If the problem cannot be solved by means of above steps, please contact your dealer or ElektroPhysik customer support.

17. Maintenance

Please keep the instrument clean. Avoid spilling solution on the instrument or on the accessories.

The inner and outer measuring cells and power leads must be kept clean to ensure error free operation.

Before filling in fresh solution, rinse the measuring cell and rubber gaskets using distilled water. If the same solution is used for the next measurement, it is sufficient to clean the bottom side of rubber gasket after each measurement.

The outer measuring cell may build up residue or metal deposits after several measurements. This generally does not affect measurement. It will be sufficient to rinse the measuring cell with distilled water.

In case of very strong pollution or routinely once a month, the outer measuring cell should be cleaned in a solution of 4 parts concentrated sulphuric acid (Caution: caustic) and one part concentrated nitric acid. They should be immersed in the solution for not longer than 10 to 15 seconds and then rinsed under running water. The procedure can be repeated if necessary until the components are clean and shiny after which they should be tried and polished.

18. Data Printer MiniPrint 4100

During printing, the GalvanoTest operating mode is switched off. For further information please refer to MiniPrint 4100 operating instructions.

19. RS 232 C Interface

GalvanoTest 3000 is equipped with an RS 232 C interface. By means of an appropriate cable, a Personal Computer, the data printer MiniPrint 4100 or a printer equipped with a suitable interface can be connected.

For data transfer to a Personal Computer a data transfer program MSoft7000 is available.

Press PRINT-key for initiating the data transfer program. Before transferring data to MiniPrint 4100, press printer ON/OFF-key for switching the printer on.

20. After sales service

Please return defective or faulty instruments to your local dealer or to ElektroPhysik for checking or repair. Please enclose a short trouble report.

21. Hints for using electrolyte solutions

- It is recommended to use solely original ElektroPhysik solutions.
- Please observe the instructions on the security data sheets 91/155/EWG (available on request).
- Improper use of electrolyte solutions may be dangerous. Therefore the user will assume all responsibility and risk in connection with it.

22. Technical specifications

Measuring principle	coulometric de-plating method
Measurable coating/base combinations	more than 70, please refer to the electrolyte selection table
Measuring range	0.05 to approx. 75 microns
De-plating speed	0.3...40 microns / min (adjustable)
Measuring unit	μm (microns) / inches (operator adjustable)
Display of readings	4-digits digital display with floating point
Alphanumerical display	16-digits display of instrument settings and operating steps
Analogue instrument	for monitoring the de-plating process
Data memory	max. 2,000 readings storable in a maximum of 18 application memories
Operation	via key pad
Data ports	RS 232 C für MiniPrint 4100, PC or other compatible printers (see section 19) analogue output for y-t writer
Power supply	switchable from 110V / 200V $\pm 10\%$ 50...60Hz / 10 Watts
Weight	instrument: approx. 2,5 kg precision holder: approx. 2,5 kg

22.1 Measuring uncertainty

Rubber gasket / mask	Diameter	Measuring area	Measuring uncertainty* in percent of reading
Rubber gasket B	2,26 mm	4 mm ²	6%
Mask C	1,13 mm	1 mm ²	9%
Mask D	0,56 mm	0,25 mm ²	20%

* The specifications are based on calibration of GalvanoTest 3000 using ElektroPhysik thickness standards.

Index

A

alphanumeric display.....D-3
analog meter.....D-3
application.....D-37, D-38
AREA.....D-4, D-12, D-40
ARROW-key.....D-12, D-34

C

C mask.....D-23, D-28
CAL.....D-4, D-14, D-34, D-35, D-36, D-40
cell holder.....D-5, D-15, D-22, D-23
Centering device.....D-23
centering device.....D-11, D-22, D-23
CLEAR-key.....D-4, D-13, D-14, D-17, D-35, D-36, D-37, D-38, D-39
concave surfaces.....D-30
connecting cable.....D-11, D-25, D-28
convex surfaces.....D-29
copper.....D-8, D-30, D-33
curvature radius.....D-41

D

D mask.....D-22, D-29
data printer.....D-3, D-4, D-9, D-10, D-11, D-20, D-21, D-39
date and time.....D-3, D-9, D-38, D-39, D-42
de-plating speed.....D-3, D-4, D-9, D-12, D-13, D-32, D-34, D-37, D-40, D-41, D-42

E

electrolyte cup.....D-7, D-9, D-11, D-12, D-23, D-24, D-25, D-26, D-28, D-29
electrolyte solution.....D-5, D-7, D-8, D-10, D-11, D-17, D-18, D-19, D-31, D-37
error sources.....D-41

I

inner measuring cell.....D-4, D-5, D-7, D-10, D-11, D-16, D-17, D-18, D-31
interface.....D-10, D-20, D-38, D-43

L

lead.....D-9, D-37

M

mask.....D-9, D-15, D-22, D-23, D-25, D-28, D-29, D-30

Measuring area.....D-12, D-25, D-26
measuring area.....D-3, D-4, D-7, D-12, D-13, D-15, D-18, D-25, D-26, D-27, D-28, D-29, D-30, D-31, D-32, D-40, D-41
measuring stand.....D-4, D-10, D-15, D-22, D-23, D-30
Measuring uncertainty.....D-37, D-45
METAL.....D-4, D-12, D-14, D-31
MiniPrint 4100.....D-3, D-4, D-9, D-10, D-11, D-20, D-21, D-32, D-34, D-39, D-42, D-43
Multi-layer.....D-30
multi-layer.....D-8, D-30

N

Nickel.....D-33
nickel.....D-8, D-9, D-30, D-32, D-33, D-36, D-39

O

outer measuring cell.....D-5, D-7, D-10, D-15, D-23, D-31, D-42

P

passivation layers.....D-31
positioning arm.....D-11, D-22, D-23
power leads.....D-42
PRINT-key.....D-3, D-21, D-38, D-43

R

reading display.....D-12, D-13, D-14, D-17, D-35, D-36, D-41
rubber gasket.....D-7, D-8, D-9, D-11, D-15, D-23, D-25, D-29, D-30, D-42

S

selection table.....D-7, D-16, D-17, D-25
SENS.....D-4, D-13, D-36, D-40
sensitivity.....D-3, D-4, D-13, D-14, D-32, D-36, D-40, D-41, D-42
SET-key.....D-3, D-12, D-13, D-14, D-26, D-27, D-34, D-35, D-36, D-39
SPEED.....D-4, D-13, D-40
default calibration.....D-14, D-35
Standard deviation.....D-37
default sensitivity.....D-36
statistics.....D-3, D-4, D-9, D-10, D-12, D-17, D-21, D-34, D-37, D-38, D-39, D-41, D-42
switch-off point.....D-36

T

test voltage.....D-3, D-36
thickness standard.....D-3, D-34
THICKNESS/VOLTAGE-key.....D-3, D-17, D-18, D-20

Tin.....D-16, D-33

tin.....D-8, D-9

V

Variation coefficient.....D-37

voltage curve.....D-3, D-9, D-19, D-20, D-32

Y

Y-T writer.....D-4

Z

Zinc.....D-16

zinc.....D-8, D-9, D-15, D-31, D-33